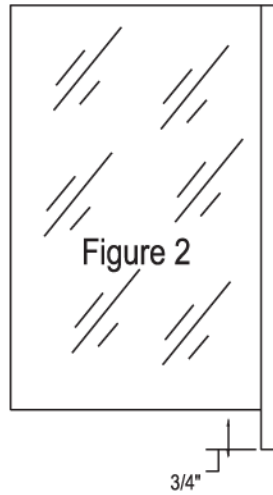
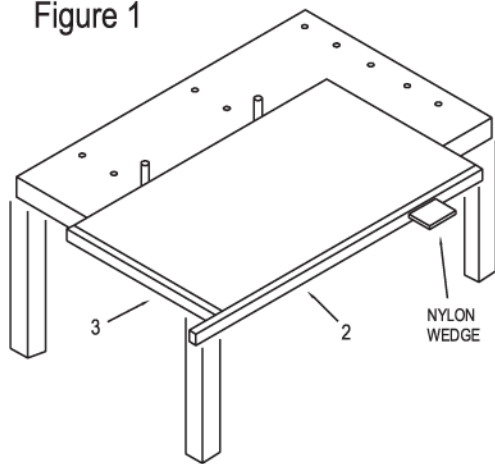

Figure 1



Note: Assembly of a hinge-left door is shown in Figure 1. For a hinge-right door, place bottom rail assembly at opposite end.

1. Lay glass flat, smooth side up on assembly table (Figure 1) and bracing glass on far side as shown so hinge rail can be driven into place. Apply hinge rail glazing channel (1) to edge of glass nearest you. Start vinyl 5/8" up from the bottom of the glass and cut flush with the top of glass.

2. The hinge jamb and hinge rail (11 & 12) are packaged assembled. Before glazing the hinge rail (2), remove hinge jamb (11) and sleeve (10) from hinge rail. Failure to do so will cause damage to metal while glazing and result in the door hinge binding. Hold hinge rail in place against vinyl with a glazing block and glaze using hammer. Hinge rail should extend 3/4" below bottom of glass (Figure 2) and be straight from end to end.

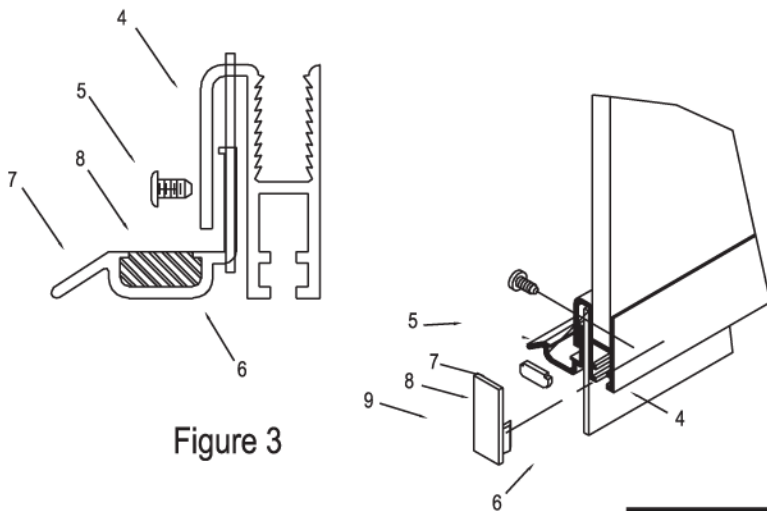

Figure 3

3. Apply bottom glazing vinyl (3) to the bottom of the glass. Hold bottom rail (4) in place against the bottom glazing channel and drive the bottom rail in place on the glass using the glazing block and a heavy steel hammer. Secure hinge rail to bottom rail using one #8 x 1 1/2" FH SMS screw (5). Start three #6 x 1/4" SMS B screws (5) into the bottom rail. Insert the splash vinyl (6) and the drip trough (7) into the bottom rail. Splash vinyl should flush off with latch end of bottom rail and butt to offset of the hinge rail at the other end. Flush-off drip trough with notchback on bottom rail at latch side. Push drip trough as far up as possible on latch side and as low as possible on hinge side and secure by tightening the three #6 x 1/4" SMS B screws (5).

4. Insert the drip plug (8) into the end of the drip trough at the handle side. Water should now drain back into the shower when the door is open. Insert the bottom rail end cap (9) in the end of the bottom rail (4) (See Figure 3).

5. Set hinge bushing (13) in place over the hinge clip (14) and push the hinge pin (12) into the hinge bushing. Drive the clip with the bushing and pin into the bottom end of the hinge jamb (See Figure 4). Slip the hinge jamb sleeve (10) over ball of hinge jamb. Place the hinge jamb with sleeve, clip, bushings and pin in place inside the hinge rail. (Screw holes in hinge jamb to the inside of door.) Slip the second pin in place in the hinge rail at the top of the door, place the bushing over the clip and drive the clip into the jamb securing the pin to the bushing.

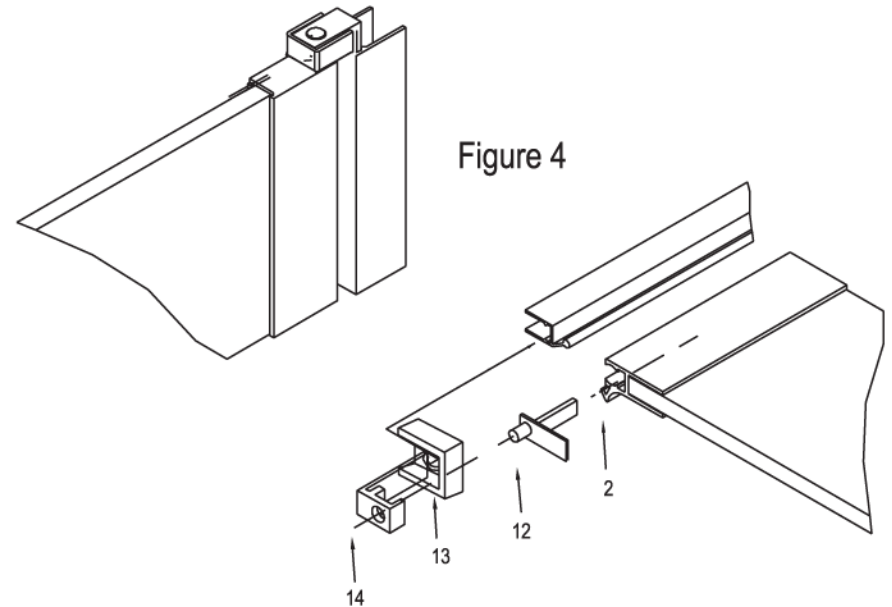
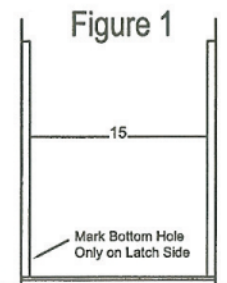

Figure 4

General: Well channels (15) are supplied 67 3/4" long. For door only installation (with no header or curb), cut with a hacksaw to 66 5/8" so they will not extend above the hinge and latch jambs.



1. Hold wall channels (15) in a plumb position and mark hole locations on the hinge side and bottom hole only on the latch side (See Figure 1). Drill holes in wall (using 3/16" carbide drill for tile walls). Insert wall anchors (16) into drilled holes.

2. Set wall channels in place and secure with #8 x 1 1/2" screws (17) using bottom screw only on latch side (See Figure 2).

Note: Door is adjustable up to 1" (1/2" at hinge jamb and 1/2" at latch jamb).

Example: A CD-24 door will fit an opening 24" to 25". The 1/2" adjustment should also be used to correct out-of-plumb conditions. For openings up to 24 1/2", set hinge jamb all the way over the wall channel and adjust latch jamb to meet door. For openings over 24 1/2" adjust hinge jamb out on wall channel to compensate for additional opening width.

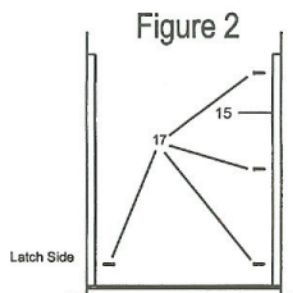

3. Set latch jamb (18) in place over wall channel, but **Do NOT Secure**.

4. Set hinge jamb with door attached (2 & 11) in place over wall channel. Adjust laterally, plumb to fit opening. Mark three holes on wall channel through the predrilled holes on hinge jamb. Drill three holes with a #31 drill bit and secure with #6 x 3/8" SMS screws (21).

5. Apply 3" vinyl channel (19) to edge of glass, centered on handle side. Tap handle (20) in place over vinyl channel.

6. Align latch jamb (18) with edge of door glass and mark wall channel (15) location on wall. Remove latch jamb and mark holes on wall. Lean wall channel to one side to allow enough room for drill and drill the remaining two holes on wall. Insert wall anchors (16).

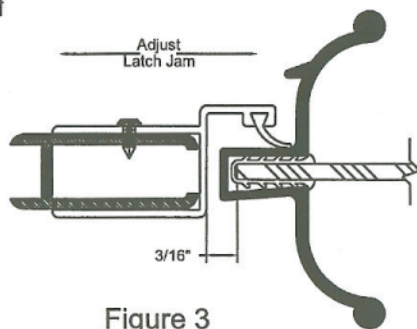

Figure 3

7. Replace wall channel and secure remaining two holes in wall channel using two #8 x 1 1/2" screws (17).

8. Replace latch jamb over wall channel. Close door and adjust latch jamb 3/6" from edge of glass (See Figure 3). Through the holes provided in the latch jamb, drill three #31 holes in wall channel. Secure latch jamb to wall channel with #6 x 3/8" SMS screws (21).

9. Set catch (22) in place on latch jamb (18) and secure with 6-32 x 3/16" screws (23).

10. Adjust drip trough (7), up at latch side of door and down at hinge side of door so water will drain into shower when door is opened. Adjust splash vinyl (6) to within 1/8" of curb.

Note: Splash vinyl should not touch curb.

11. Clean area to where sealant is to be applied and run a bead of sealant full length inside and outside of each wall channel, where channel meets wall. Allow sealant to cure for 24 hours.

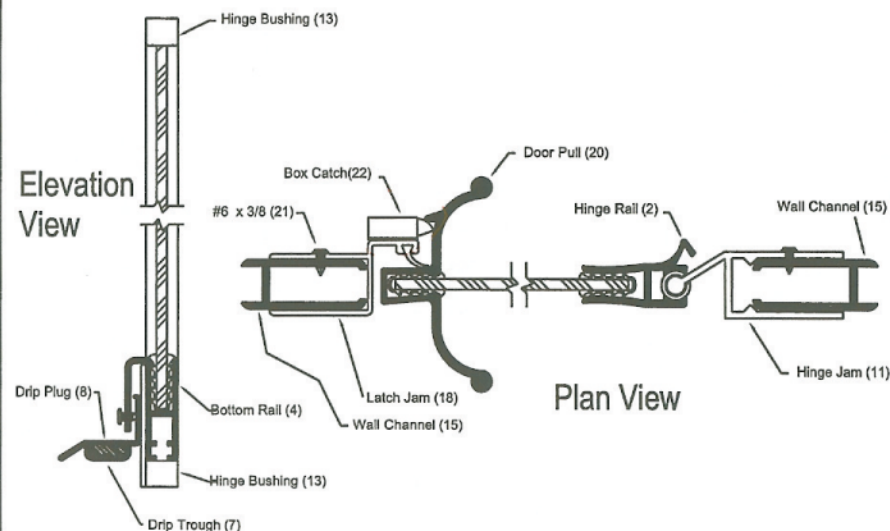

Continuous Hinge Shower Enclosure

Installation Instructions

Model **IMST-135-36/38**

When ordering repair parts, please give the following information:

1. Model Number
2. Part Number
3. Part Description
4. Color

To install your shower enclosure, you will need the following:

- Level
- #31 Drill Bit
- Glazing Block
- Hack Saw
- 3/16" Carbide Drill Bit (for the tile walls)
- Phillips Screwdriver
- Silicone

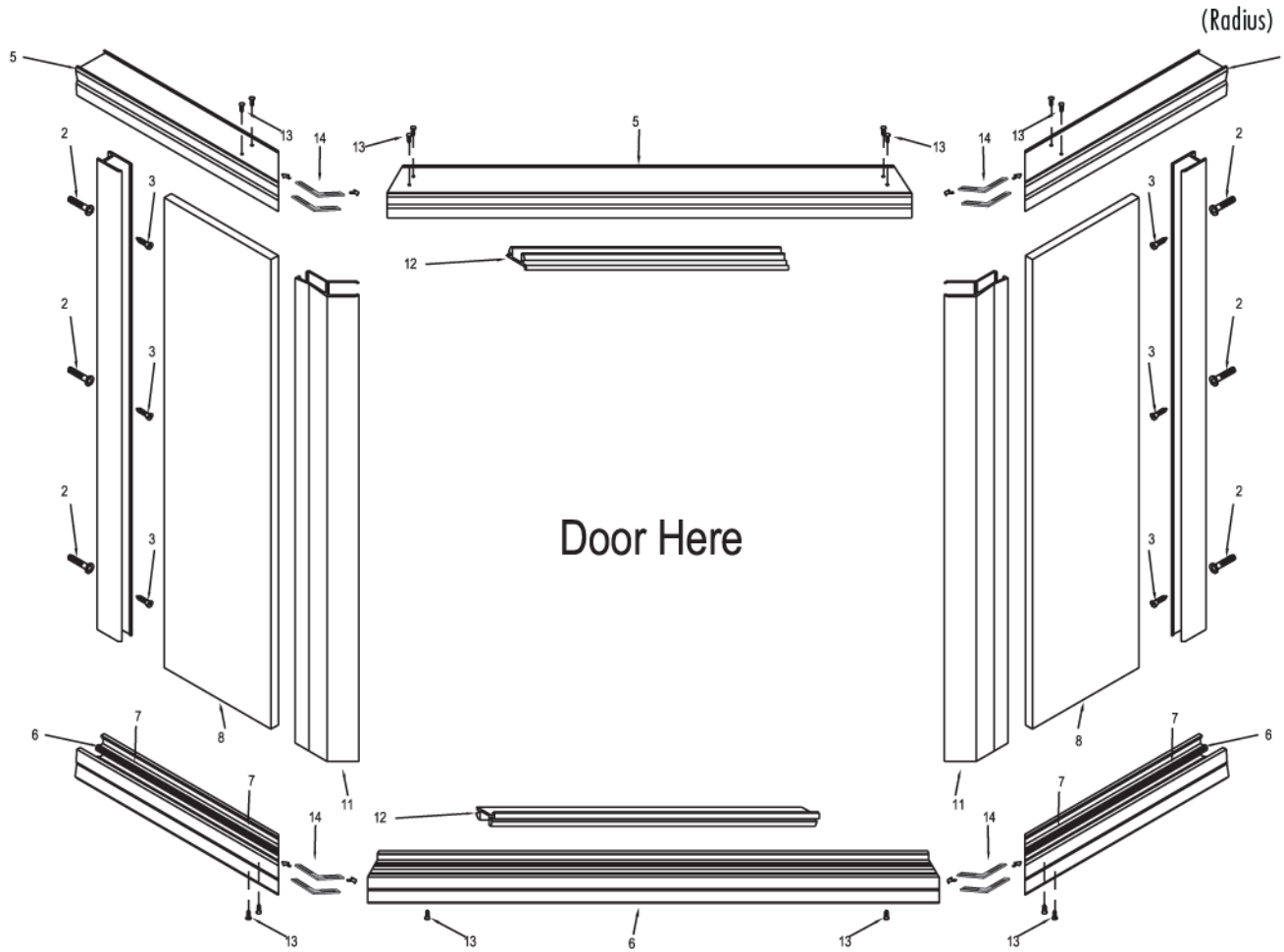

Door Here

*Note: Numbers 1, 2 & 3 come with door stall wrap

Description	Qty	Part No.	Picture
1. Wall Channels*	2	ZD-1006	
2. Wall Anchors*	6	ZV-935	
3. #8 x 1 1/4" Screws*	6	#8 x 1 1/4"	
4. #6 x 3/8" Screws	26	#6 x 3/8"	
5. Headers-Mitered 22.5 Degrees	3	ZSS-2101	
6. Curbs-Mitered 22.5Degrees	3	ZSS-3101	
7. Glass Support Blocks	4	ZV-902	
8. 135-Degree Glass Panel	2		
9. Vertical Seal Vinyl	8	ZV-909	
10. Horizontal Seal Vinyl	8	ZV-906	
11. 135-Degree Corner Post	2	ZSS-1105	
12. Header and Curb Fillers	2	ZSS-1102	
13. 135-Degree Header/Curb Clips	8	ZC-135	

NOTE: Wall channels (1), wall anchors (2) and screws (3) that are used in stall shower installation are shipped with the shower door. Read both door and stall instructions before starting installation.

1. Add 3/8" to centerline measurement for center section, and 3/16" to centerline measurement for sides. Cut both header and curb center sections to size, also cut the curb side sections, leaving the header sections for later.

2. Assemble header and curb with clips provided (Figure 1).

Using holes provided in header and curb.

Secure using eight #6 X 3/8" SMS Screws (13).

Set curb in place and mark location on curb leaving curb in place temporarily.

3. Set wall channels into curb and mark holes on wall. Remove wall channels and curb and drill holes into wall using 3/16" drill bit. Place screw anchors into holes.

4. Run a 1/4" bead of silicone on underside of curb, over miters, and where the ends of the curb sits on the threshold.

5. Replace curb and silicone where miters are and where curb meets wall. Replace the wall channels and secure using #8 X 1 1/4" SMS.

6. Place glass support blocks in curb and set panel glass in place, tacking at top with about 6" of the vertical seal vinyl. To adjust for wall conditions, adjust the panel in or out of the post, making sure that at least 1/4" remains in each channel.

7. Place corner post in place on other edge of glass and tack in place using vertical seal vinyl. Plumb corner post to the respective wall.

8. Check the chart for the door size, and obtain the range for the curb filler. If the distance between the wall channel and the corner post falls within this range then cut curb filler to size. If the measurement does not fall into the range, then a larger or smaller door is needed. Cut curb filler to size and snap in place with higher lip to outside of unit.

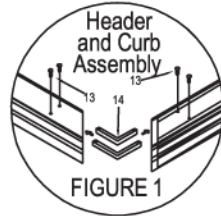

FIGURE 1

9. To cut header sides to length, measure from wall to the outside point of angle on corner post, then add 1/8" to this measurement. This is the length of the outside dimension of the header from miter point to the wall

(Refer to Shower Door Installation Instructions.)

10. Snip excess vinyl from latch jamb, and crimp in place at top and bottom. Holding corner post, slip latch jamb into place.

11. Install 3" vinyl channel, centered on edge of glass and tap handle in place.

12. Set door (with hinge jamb attached) over corner post. Secure hinge jamb to corner post using adjustment derived at from step #8. Use a #31 drill bit and #6 X 3/8" SMS.

13. Stand inside shower and pull door closed. If, when you pull the door closed without creating pressure on the latch jamb vinyl, there is an opening at the top, you must decrease the length of the header over the fixed panel side where the door is hanging. If the gap is at the bottom then you need to shorten the length of the header over the fixed panel where the door latches.

14. Using a #31 latches and #6 X 3/8" SMS to secure header to wall channels.

15. Adjust header up or down on corner post to make parallel with top of door. Now using a #31 drill secure with #6 X 3/8" SMS to corner post.

16. Install rest of vertical seal vinyl at post and wall channels, and horizontal seal vinyl in header and curb.

17. Recheck alignment of door and corner post, if out, adjust by tapping on corner post.

18. Adjust latch jamb for a gap of 3/16" for latch to edge of door.

19. Install magnet on latch jamb.

20. Adjust splash vinyl so that approximately 1/8" daylight space remains between bottom of splash vinyl and curb filler with the door in a closed position.

21. Seal along inside and outside edge of metal and tile with silicone.

Header & Curb Fillers		
Min. Filler=Door Size-1 7/8"		
Max. Filler=Door Size-1 7/8"		
Model Number	Min.	Max.
CD-20	18 1/8"	19 1/8"
CD-21	19 1/8"	20 1/8"
CD-22	20 1/8"	21 1/8"
CD-23	21 1/8"	22 1/8"
CD-24	22 1/8"	23 1/8"
CD-25	23 1/8"	24 1/8"
CD-26	24 1/8"	25 1/8"
CD-27	25 1/8"	26 1/8"
CD-28	26 1/8"	27 1/8"
CD-29	27 1/8"	28 1/8"
CD-30	28 1/8"	29 1/8"
CD-31	29 1/8"	30 1/8"
CD-32	30 1/8"	31 1/8"
CD-33	31 1/8"	32 1/8"
CD-34	32 1/8"	33 1/8"
CD-35	33 1/8"	34 1/8"
CD-36	34 1/8"	35 1/8"

